

DATASHEET

HALFCOUPLER 10KG / 20MM

■ Art.Nr. 151 35 110 11 T
 ■ Art.Nr. 151 35 110 10 T

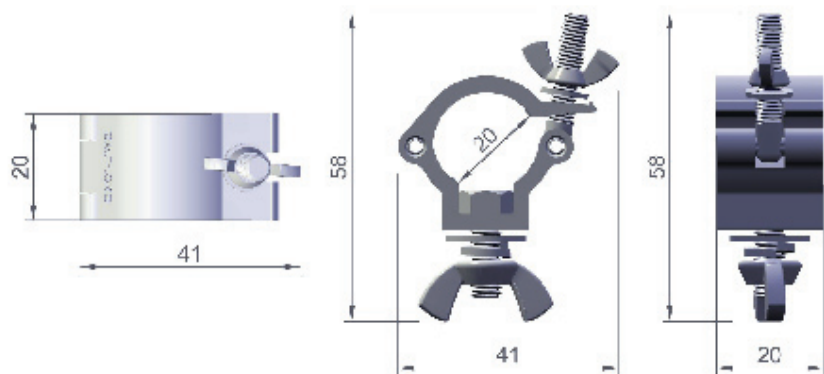

Rohrdurchmesser <i>Tube</i>	20 mm
Belastbarkeit (SWL) <i>Tensile load</i>	10 kg
Farbe <i>Colour</i>	silber / schwarz <i>silver / black</i>
Bauform <i>Variaty</i>	Halbschelle <i>halfcoupler</i>
Verschluss <i>Screw plug</i>	M5 Flügelmutter, Unterlegscheibe <i>M5 wing nut</i>
Abgang <i>Retaining screw</i>	M6 Geräteschraube, Flügelmutter <i>M6 bolt, wing nut</i>
Breite <i>Width</i>	20 mm
Zugbelastung <i>Tensile load</i>	10 kg
Material <i>Material</i>	Aluminium 6061 T6
Gewicht <i>Weight</i>	0,039 kg
Verpackungseinheit <i>Unit</i>	200 Stück <i>200 pieces</i>