

DATASHEET

HALFCOUPLER 100KG / 50MM

Art.Nr. 151 50 100 10 T

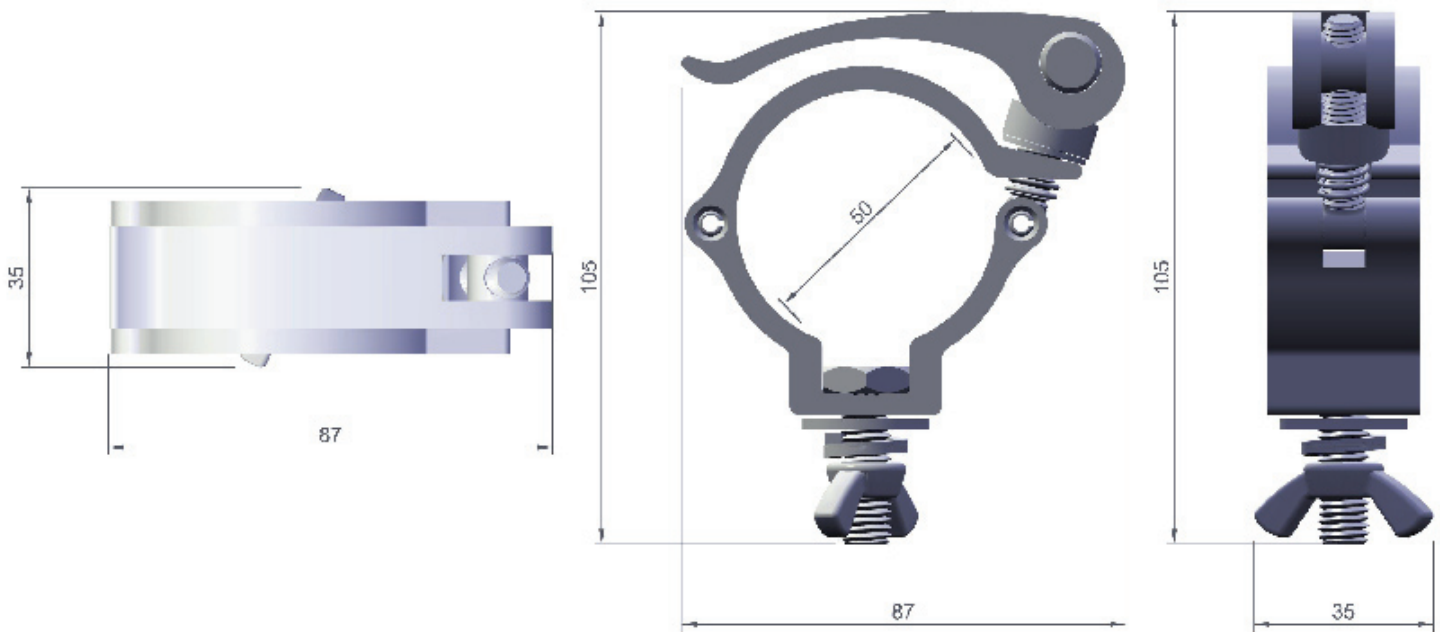

Rohrdurchmesser <i>Tube</i>	48-51 mm
Belastbarkeit (SWL) <i>Tensile load</i>	100 kg
Farbe <i>Colour</i>	silber <i>silver</i>
Bauform <i>Variaty</i>	Halbschelle <i>Halfcoupler</i>
Verschluss <i>Screw plug</i>	M8 Spannbügel, Unterlegscheibe <i>M8 spring clip, washer</i>
Abgang <i>Retaining screw</i>	M10 Geräteschraube, Flügelmutter <i>M10 bolt, wing nut</i>
Breite <i>Width</i>	30 mm
Zugbelastung <i>Tensile load</i>	100 kg
Material <i>Material</i>	Aluminium 6061 T6
Gewicht <i>Weight</i>	0,19 kg
Verpackungseinheit <i>Unit</i>	60 Stück <i>60 pieces</i>