

# DATASHEET

## SWIVELCOUPLER 100KG / 50MM

■ Art.Nr. 151 50 100 ST  
 ■ Art.Nr. 151 50 100 ST BK

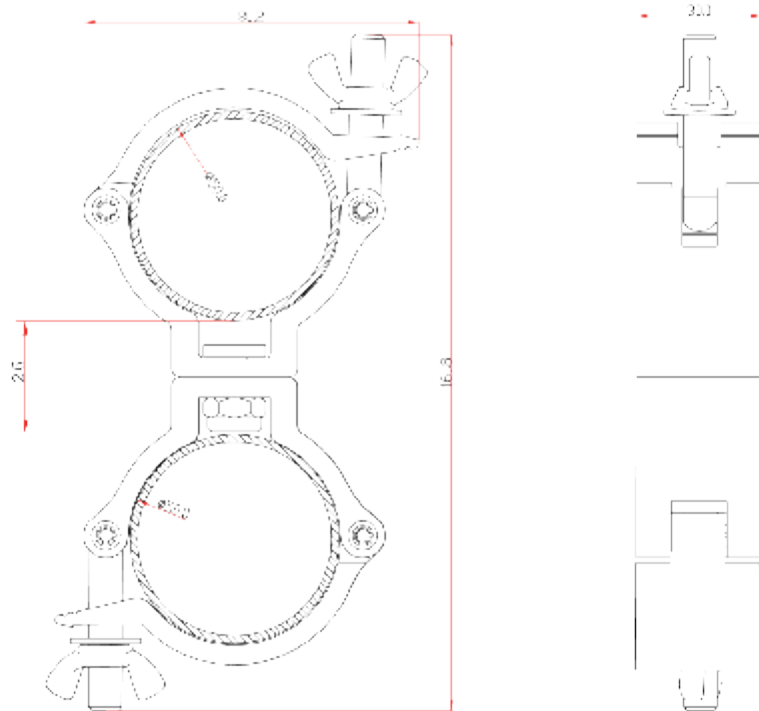

<b>Rohrdurchmesser</b> <i>Tube</i>	48-51 mm
<b>Belastbarkeit (SWL)</b> <i>Tensile load</i>	100 kg
<b>Farbe</b> <i>Colour</i>	silber / schwarz <i>silver / black</i>
<b>Bauform</b> <i>Variaty</i>	360° drehbar <i>360° rotatable</i>
<b>Verschluss</b> <i>Screw plug</i>	M8 Flügelmutter, Unterlegscheibe <i>M8 wing nut</i>
<b>Abgang</b> <i>Retaining screw</i>	50 mm Coupler, durch Bolzen verbunden, 360° drehbar <i>50 mm coupler, connected by pin, 360° rotatable</i>
<b>Breite</b> <i>Width</i>	30 mm
<b>Zugbelastung</b> <i>Tensile load</i>	100 kg
<b>Material</b> <i>Material</i>	Aluminium 6061 T6
<b>Gewicht</b> <i>Weight</i>	0,242 kg
<b>Verpackungseinheit</b> <i>Unit</i>	30 Stück <i>30 pieces</i>