

DATASHEET

QUICK-MULTICLAMP 50KG / 35MM

■ Art.Nr. 151 50 250 11 Q
 ■ Art.Nr. 151 50 250 12 Q

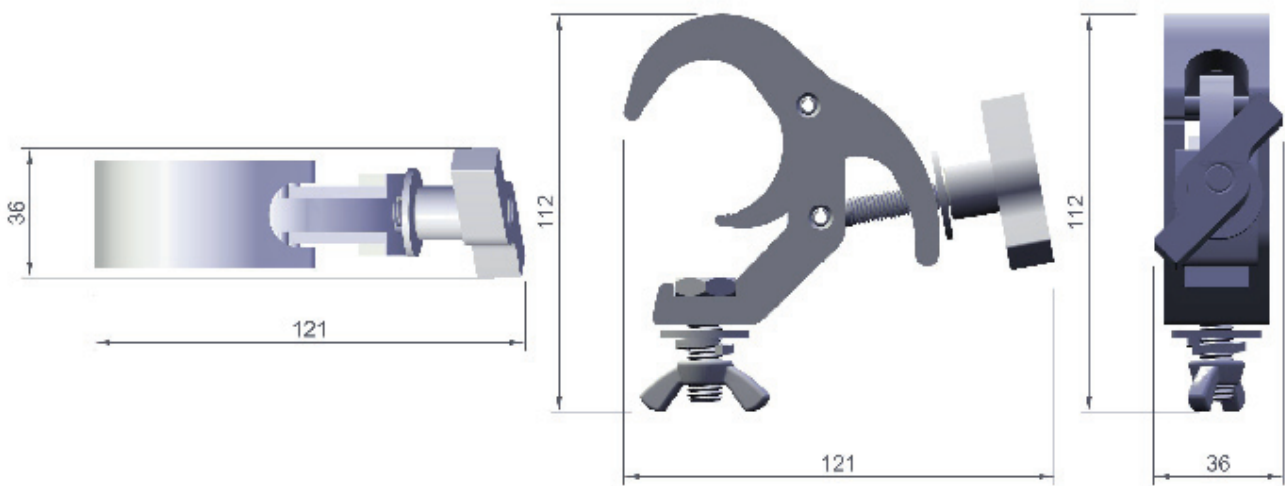

Rohrdurchmesser <i>Tube</i>	35-41 mm
Belastbarkeit (SWL) <i>Tensile load</i>	50 kg
Farbe <i>Colour</i>	silber / schwarz <i>silver / black</i>
Bauform <i>Variaty</i>	Schnellspann-Klemme <i>Quick-lock clamp</i>
Verschluss <i>Screw plug</i>	M8 Flügelmutter groß, Unterlegscheibe <i>M8 wing nut big, washer</i>
Abgang <i>Retaining screw</i>	M10 Geräteschraube, Flügelmutter <i>M10 bolt, wing nut</i>
Breite <i>Width</i>	30 mm
Zugbelastung <i>Tensile load</i>	50 kg
Material <i>Material</i>	Aluminium 6061 T6
Gewicht <i>Weight</i>	0,269 kg
Verpackungseinheit <i>Unit</i>	35 Stück <i>35 pieces</i>