

# DATASHEET

## HALFCOUPLER 500KG / 50MM

Art.Nr. 151 50 500 10 TT

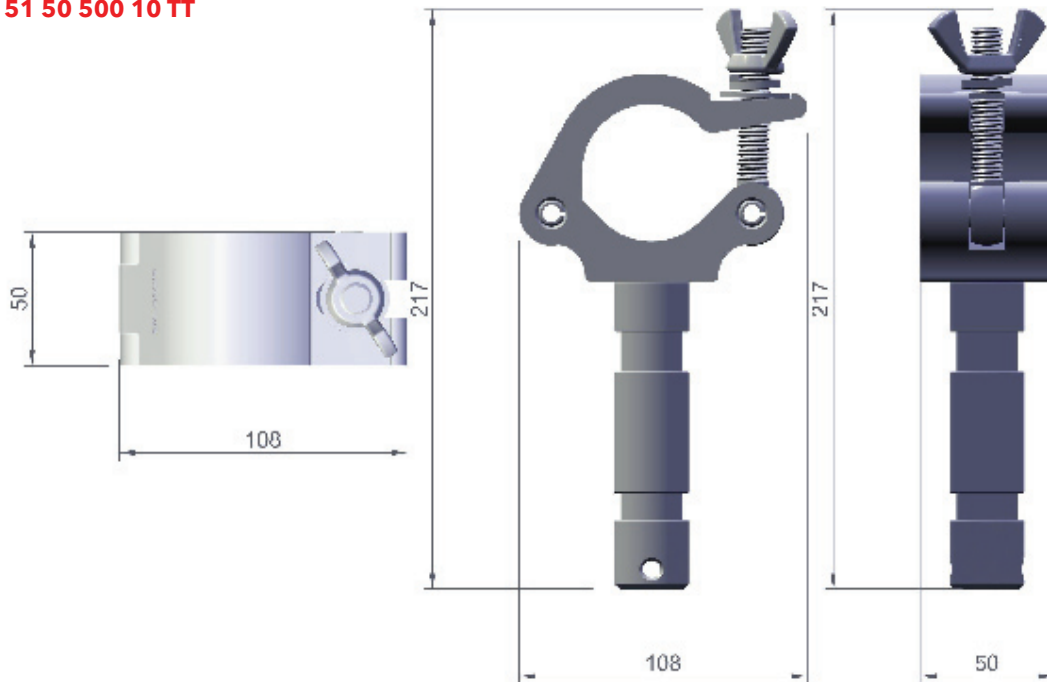

|   |   |
|---|---|
| <b>Rohrdurchmesser</b><br><i>Tube</i>             | 48-51 mm  |
| <b>Belastbarkeit (SWL)</b><br><i>Tensile load</i> | 500 kg  |
| <b>Farbe</b><br><i>Colour</i>                     | silber<br><i>silver</i>   |
| <b>Bauform</b><br><i>Variaty</i>                  | Halbschelle mit TV-Zapfen<br><i>Halfcoupler with spigot</i>                       |
| <b>Verschluss</b><br><i>Screw plug</i>            | M12 Flügelmutter, Unterlegscheibe<br><i>M12 wing nut, washer</i>                  |
| <b>Abgang</b><br><i>Retaining screw</i>           | M10 Senkkopfschraube, angeschraubter TV-Zapfen<br><i>M10 bolt, screwed spigot</i> |
| <b>Breite</b><br><i>Width</i>                     | 50 mm   |
| <b>Zugbelastung</b><br><i>Tensile load</i>        | 500 kg  |
| <b>Material</b><br><i>Material</i>                | Aluminium 6061 T6   |
| <b>Gewicht</b><br><i>Weight</i>                   | 0,70 kg   |
| <b>Verpackungseinheit</b><br><i>Unit</i>          | 15 Stück<br><i>15 pieces</i>  |