

DATASHEET

HALFCOUPLER 200KG / 50MM

■ Art.Nr. 151 50 500 14 TR
 ■ Art.Nr. 151 50 500 14 TR BK

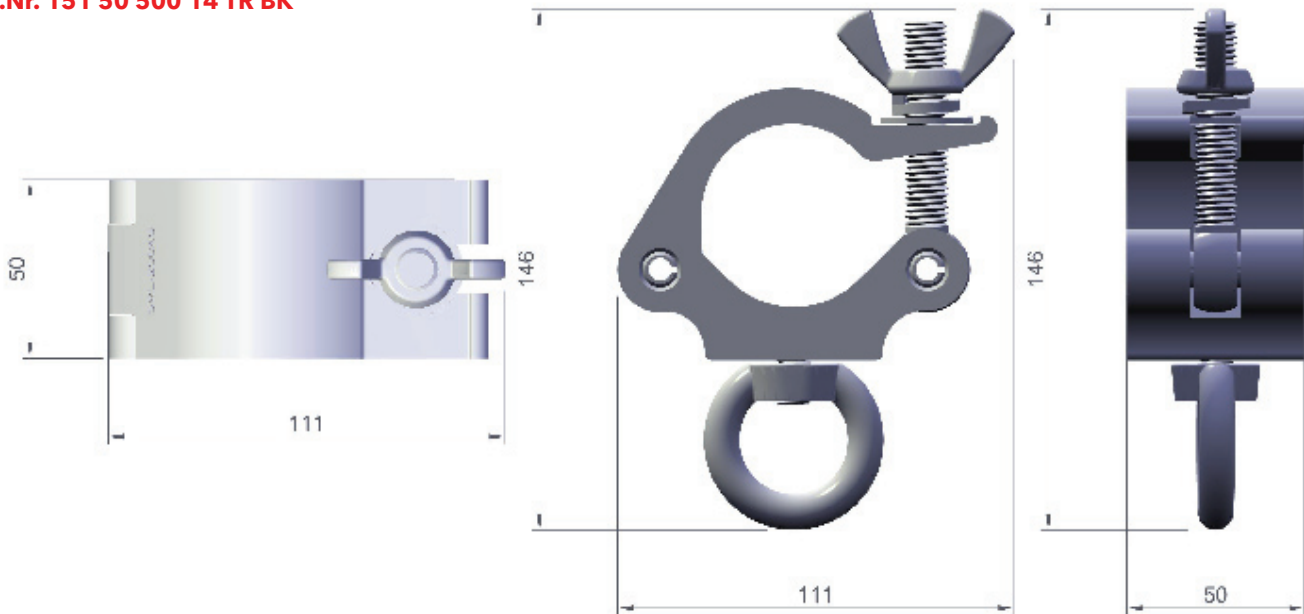

Rohrdurchmesser <i>Tube</i>	48-51 mm
Belastbarkeit (SWL) <i>Tensile load</i>	200 kg
Farbe <i>Colour</i>	silber / schwarz <i>silver / black</i>
Bauform <i>Variaty</i>	Halbschelle mit Ringmutter M10 <i>Halfcoupler with ring nut M10</i>
Verschluss <i>Screw plug</i>	M12 Flügelmutter, Unterlegscheibe <i>M12 wing nut, washer</i>
Abgang <i>Retaining screw</i>	M10 Senkkopfschraube, angeschraubte Ringmutter <i>M10 bolt, screwed ring nut</i>
Breite <i>Width</i>	50 mm
Zugbelastung <i>Tensile load</i>	200 kg
Material <i>Material</i>	Aluminium 6061 T6
Gewicht <i>Weight</i>	0,61 kg
Verpackungseinheit <i>Unit</i>	25 Stück <i>25 pieces</i>