

DATASHEET

SWIVELCOUPLER 500KG / 50MM

■ Art.Nr. 151 50 502 ST
 ■ Art.Nr. 151 50 502 ST BK

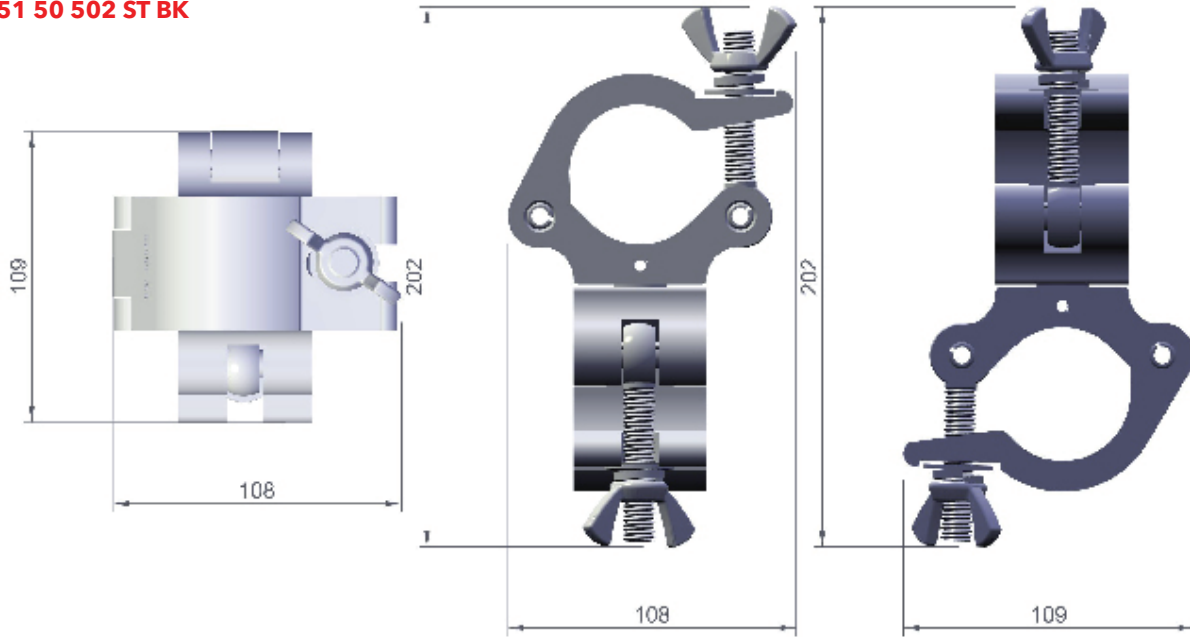

Rohrdurchmesser <i>Tube</i>	48-51 mm
Belastbarkeit (SWL) <i>Tensile load</i>	500 kg
Farbe <i>Colour</i>	silber / schwarz <i>silver / black</i>
Bauform <i>Variaty</i>	90° fixiert <i>90° fixed</i>
Verschluss <i>Screw plug</i>	M12 Flügelmutter, Unterlegscheibe <i>M12 wing nut</i>
Abgang <i>Retaining screw</i>	50 mm Coupler, durch Bolzen verbunden, 90° fixiert <i>50 mm coupler, connected by pin, 90° fixed</i>
Breite <i>Width</i>	50 mm
Zugbelastung <i>Tensile load</i>	500 kg
Material <i>Material</i>	Aluminium 6061 T6
Gewicht <i>Weight</i>	1,09 kg
Verpackungseinheit <i>Unit</i>	10 Stück <i>10 pieces</i>